

# FOOD WASTE DISPOSER OWNER'S GUIDE

**IMPORTANT** - Read all instructions thoroughly.

Keep this guide for future reference.

**CAUTION** - Be sure to review **SAFETY INSTRUCTIONS PERTAINING TO A RISK OF FIRE, ELECTRICAL SHOCK OR INJURY TO PERSONS** before installing disposer.

Our food waste disposer is a reliable appliance that will offer your household many years of trouble free use. This disposer has been uniquely designed to free your kitchen of all organic food waste left over after the preparation and clean-up of meals. Simply turn on the water, switch the disposer on, put your food waste in the disposer and it will shred the garbage into very fine particles that are easily flushed through the sewer system without any problem. For Batch Feed Operations, please see Section 6 of this manual.

Before installing and operating this disposer:

1. Make sure that the installation of this appliance is allowed by the authorities.
2. Please read and follow all recommendations in this manual to ensure trouble free operations.

If you have any questions, please contact your retailer.

## Table of contents

- 1 MOUNTING ASSEMBLY
- 2 ELECTRICAL CONNECTIONS
- 3 OVERFLOW/APPLIANCE CONNECTIONS
- 4 ATTACHING THE DISCHARGE ELBOW
- 5 CONNECTING DISPOSER TO MOUNT ASSEMBLY
- 6 OPERATING INSTRUCTIONS
- 7 TROUBLESHOOTING
- 8 CLEANING AND MAINTENANCE
- 9 ELECTRICAL INFORMATION



[www.franke.co.uk](http://www.franke.co.uk)



# Important Safety Instructions

Instructions pertaining to risk of fire, electric shock or injury to persons.

Save these instructions.

WARNING - When using electrical appliances, basic precautions should always be followed, including the following:

1. Read all instructions before using the appliance.
2. To reduce the risk of injury, close supervision is necessary when an appliance is used near children.
3. Do not put fingers or hands into a waste disposer while it is functioning.
4. Turn the power switch to the off position before attempting to clear a jam or remove an object from the disposer.
5. When attempting to loosen a jam in a waste disposer, use a long wooden utensil e.g. spoon.
6. When attempting to remove objects from a disposer, use long-handled tongs or pliers.
7. To reduce the risk of injury please note:
  - this disposer is not for grinding hard materials, such as glass and metal;
  - this disposer must be connected to the electric supply by means of either a power supply cord or insulated wires in a flexible conduit;
  - when installing the disposer, care must be taken to ensure that the reset button of the overload protection device remains readily accessible.
8. Additionally for continuous feed models:
  - Care must be taken to ensure that the supply is disconnected by switching off the electric supply or by removing the plug from the socket-outlet before freeing a jammed rotor (as describe in step 5).
  - When not operating the disposer, leave the stopper in place to reduce the risk of objects falling into the disposer.
  - **Do not operate disposer unless splash guard is in place.**
9. **For proper electrical earth instructions see the ELECTRICAL CONNECTION details of this manual.**
10. All installations should be carried out by a qualified electrician.
11. The symbol  on the product or on its packaging indicates that this product may not be treated as household waste. Instead, it shall be handed over to the applicable environmental collection point for the recycling of electrical and electronic equipment. For more detailed information about recycling of this product, please contact your local authority, your household waste disposal service or the shop where you purchased the product.

# 1. Components and Installation of mount assembly

PLEASE READ BEFORE INSTALLATION

NB: Pay close attention to the order of mount assembly parts, as they have been correctly assembled by the factory. (See 1A and 1B.)

- Disassemble the mounting assembly, as it has been shipped, by turning the sink flange until the projections align with the notches in the mount ring and allow you to pull the sink flange up and out of the remaining mount assembly. Note the sequence of these parts as they are stacked and refer to 1A and 1B to identify each part. Unpack the 3 mount screws and screw them half way through the mount ring (notice "THIS SIDE UP" is imprinted on top of the mount ring).  
Next, stack the rubber gasket on top of the protector ring and sit them on top of the pointed ends of the mount screws.
- Keep these assembled parts together and set aside. Before you connect the disposer to the mount assembly under the sink, you may want to practice engaging the groove of the Hush Cushion® to the ridge at the bottom of the sink flange (see 1A and read Sec. 6).
- Be sure your sink is clean. Pack the underside rim of the flange with putty (see 1C). Position the sink flange so it is centred and readable as you look into your sink. Push the sink flange firmly into the sink opening to make a good seal. DO NOT move or rotate the sink flange once seated or the seal may be broken.
- Take the remaining portion of the mount assembly, as it was set aside and make sure that the rubber gasket is on top of the protector ring. From under the sink, while holding the sink flange firmly with one hand, line up the notches in the mount ring with the projections of the sink flange. Slide the mount assembly up onto the sink flange, past the projections and give the mount assembly a 1/4 turn, so that it will hang by itself (see 1D).
- Tighten the 3 mounting screws evenly with a screwdriver (see 1E). DO NOT OVERTIGHTEN! Trim off excess putty.

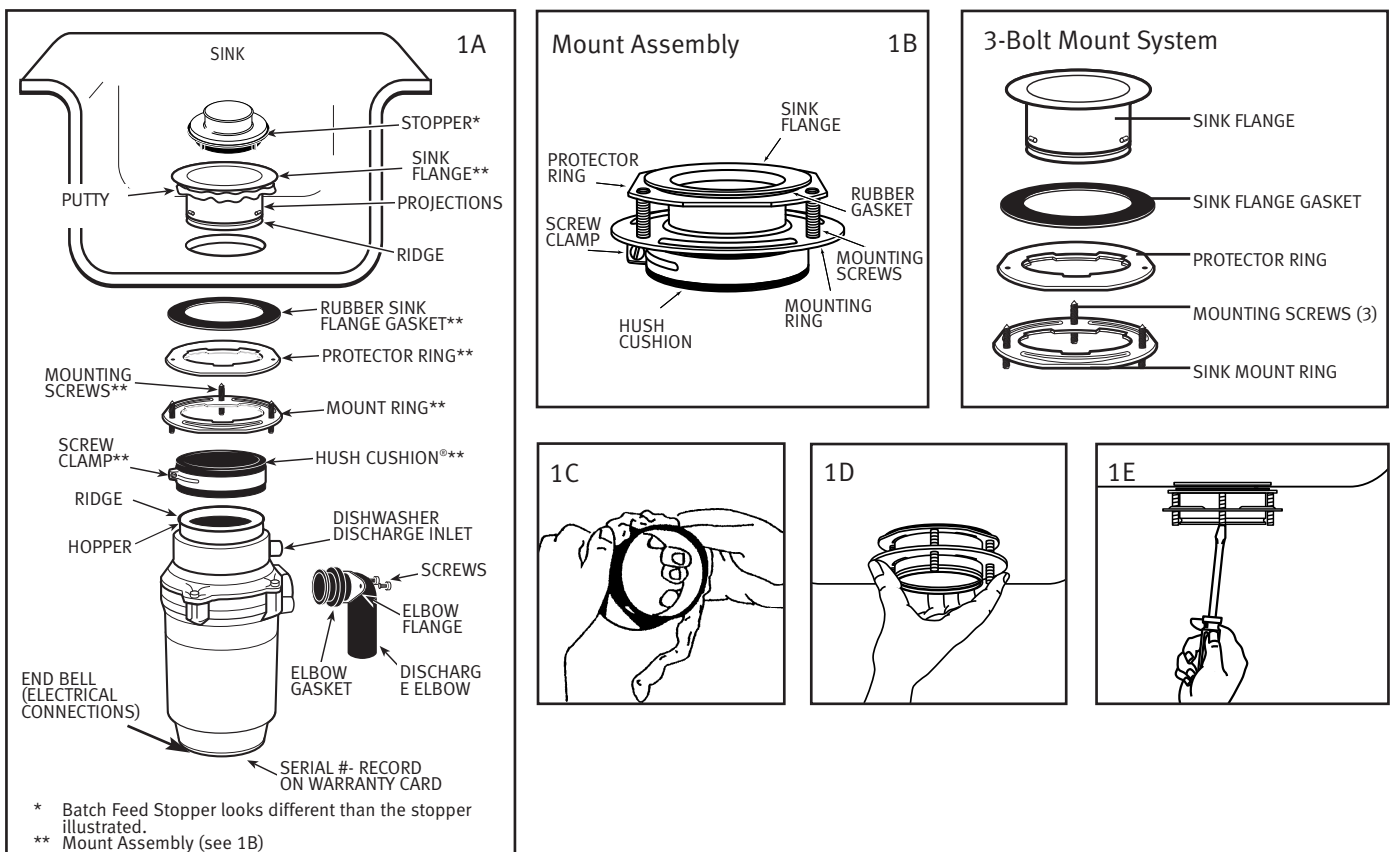

## 2. Electrical Supply

**WARNING: THIS APPLIANCE MUST BE EARTHED.**

This disposer is rated at 220–240V~, 50/60 Hz and should be connected to a main distribution board or consumer unit.

Always use a qualified electrician for all installations.

FOR MODELS WITH PROVIDED PRE-WIRED MOULDED PLUG AND LEAD (SEE 2A)

This disposer is designed to be connected to a 220–240V~50/60Hz electrical supply through a three-pin plug and socket. The disposer must be protected by a BS 1362 13 Amp fuse. This is already supplied in the moulded plug and lead, attached to the disposer.

### For Batch Feed Models:

Simply plug the disposer into a 13 Amp plug socket, located conveniently below the sink.

### For Continuous Feed Models:

Connect to air switch provided or alternatively use the same 13 Amp plug socket for the batch feed models, except switch the supply to this socket with a 13 Amp double pole switched spur. This spur switch should be situated conveniently above the work surface, at least a metre away from the side of the sink unit, away from splashes and out of reach of children. The spur switch used must be a double pole type with at least 3mm contact separation in each pole (20 Amp DP switches to BS 3676 meet this requirement).

To help prevent accidentally leaving the disposer running, a switch with a neon indicator lamp is advised. A 13 Amp ASTA approved fuse, to BS 1362, must be fitted in the fuse carrier of this spur switch.

### Electrical connections:

If your disposer was manufactured with a prewired moulded plug and lead, simply insert the plug into the socket.

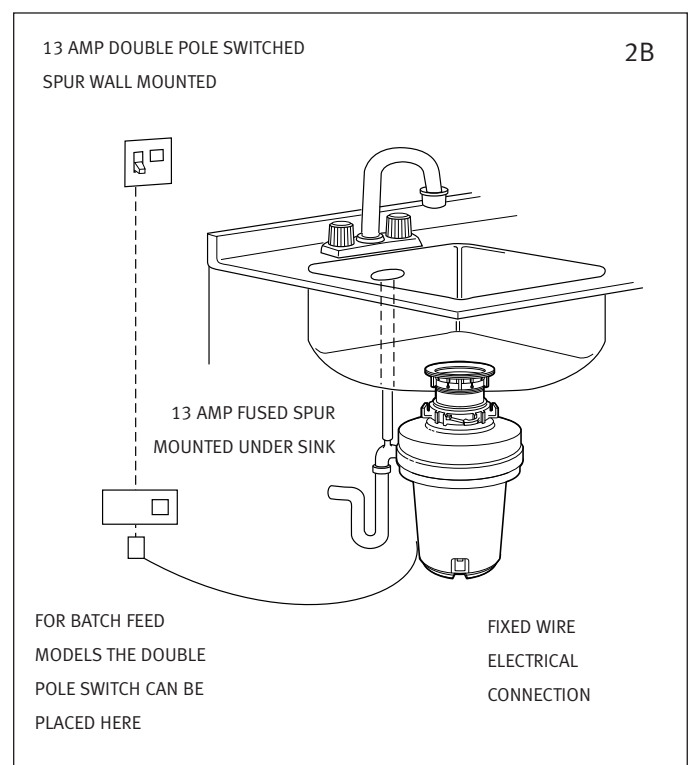
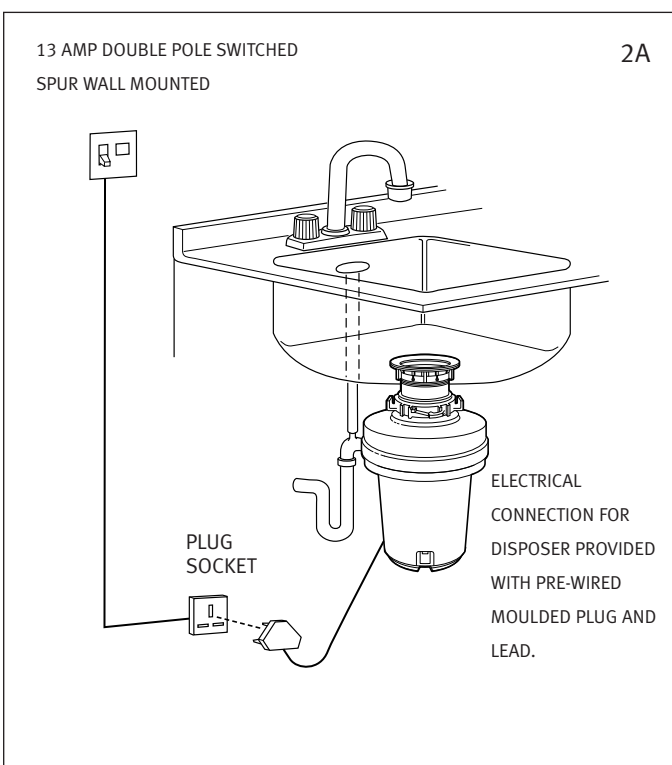

### 3. Overflow/Appliance Connections

For overflow or dishwasher connection complete the following procedure. Alternatively go to step 4.

- A. Using a blunt instrument (steel punch or wooden dowel), knock out entire plug (see 3A). Do not use a screwdriver or sharp instrument. When knockout plug falls into disposer, you may remove it or simply grind it up when the disposer is used. This will not damage the disposer in any way, but may take some time to grind, over the course of several uses.
- B. Connect overflow or hose using hose clamp. If hose size is different, you will need a stepped rubber adaptor.

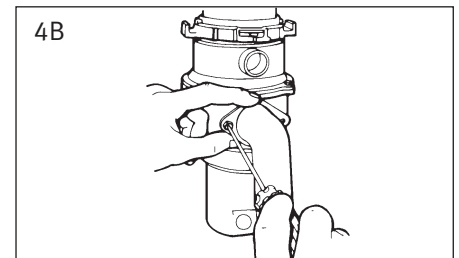
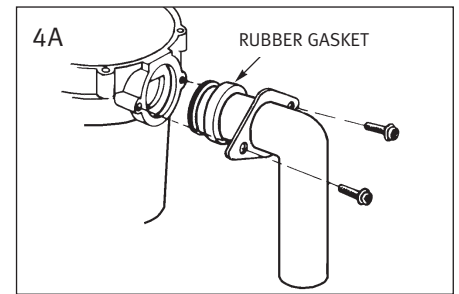
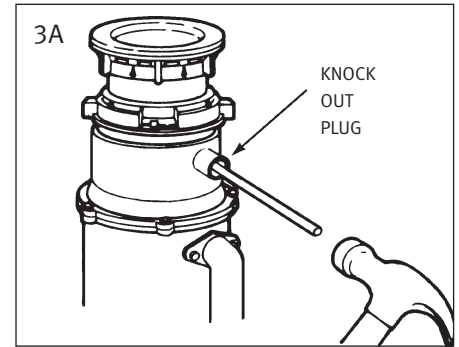

### 4. Attaching discharge elbow

- A. Connect waste elbow to disposer (see 4A), proceed to step 5 and then connect bottom of elbow by tightening slip nut.
- B. Make sure all plumbing connections are tight (see 4B).

### 5. Connecting disposer to mount assembly

3-BOLT MOUNT (See section 3 for your mount type.)

- A. Press firmly around the Hush Cushion® to ensure it is engaged with the neck of the disposer.
- B. Lubricate the top inside lip of the rubber Hush Cushion® with a liquid soap.
- C. Line up discharge elbow of disposer with trap under mounting assembly. Guide disposer up and engage the groove of the Hush Cushion® around the ridge at the bottom of the sink flange (see 5A & refer back to 1B). While still supporting the disposer, tighten the screw-clamp around Hush Cushion®. The disposer will now hang by itself.
- D. If you need to turn the disposer make sure the sink flange does not turn. It will break the seal created when installed. Go back to steps 5A and 5B.

**IMPORTANT – PLEASE READ**  
Do not remove clamp from Hush Cushion® or Hush Cushion® from hopper. Both parts are factory installed and installation ready.

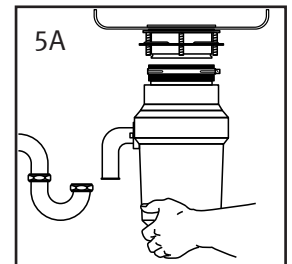

Lubricate top angled surface of rubber Hush Cushion® with liquid soap prior to engaging disposer to sink flange. Fit Hush Cushion® lip into sink flange groove using a slight rocking motion. Tighten clamp (see 5B).

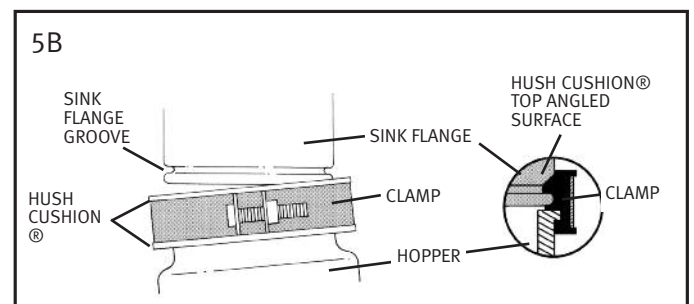

## 6. Operating Instructions

This disposer utilises anti-jam swivel impellers that make a clicking sound as they swing into place. This indicates normal operation.

### Continuous Feed Models:

- A. Remove sink stopper. Turn on cold water using a medium flow.
- B. Turn switch to ON position; your motor is turning at full speed and ready to use.
- C. Scrape in food waste. Down the drain go table scraps, peelings, cobs, rinds, seeds, pits, bones and coffee grounds. To speed up food waste disposal, cut or break up large bones, rinds and cobs. Large bones and fibrous husks require considerable grinding time and are more easily thrown away with other trash. Do not be alarmed that the disposer slows down while grinding. The disposer is actually increasing torque (grinding power) and is operating under normal conditions.
- D. Before turning disposer off, let water and disposer run for approximately 25 seconds after shredding stops. This assures that all waste is thoroughly flushed through trap and drain.
- E. It is not recommended to use hot water while running disposer. Cold water will keep food waste and fats solid so disposer can flush away particles.

### Batch Feed Models:

- A. Remove sink stopper and turn on a medium flow of cold water (see 6A).
- B. Scrape in food waste. Down the drain go table scraps, vegetable peelings, cobs, rinds, pits, bones and coffee grounds (see 6B).
- C. Insert stopper to start disposer. One of the two small slots in stopper base must line up with switch plunger inside the neck of the disposer (see 6C). Push down firmly. Lift stopper to shut disposer off.
- D. Run disposer and water for 25 seconds after shredding stops. This assures that all waste is thoroughly flushed through trap and drain.
- E. To fill sink, insert stopper so that largest slot lines up with switch plunger (see 6D). Stopper can now be pushed down to seal sink without actuating disposer. When medium sized slot (see 6C) in stopper base is lined up with the switch plunger, water can drain, but tableware, etc., cannot be accidentally dropped into disposer.

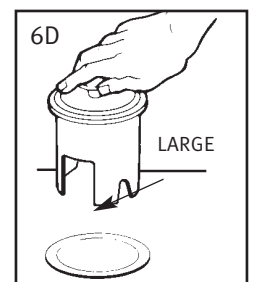
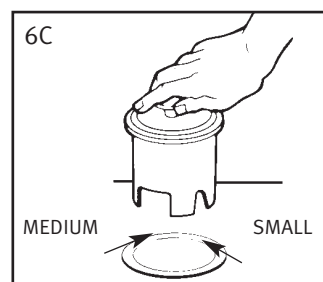
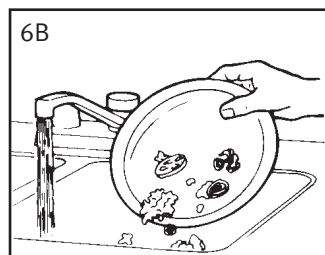
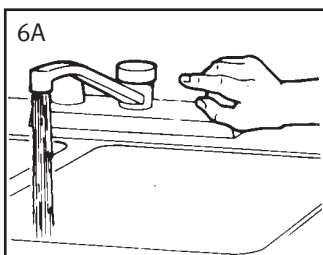

### Tips – Helpful hints

1. Be sure disposer is empty before using other appliances attached so it may drain properly.
2. You may want to leave the stopper in the drain when not in use to prevent utensils and foreign objects from falling into the disposer.
3. Use it wisely! Your disposer is ruggedly built to give you years and years of trouble-free service. It will handle all normal food wastes – BUT it will not grind and dispose such items as tin cans, bottles and bottle caps, glass, china, leather, cloth, crockery, rubber, string, feathers, or mussels or oyster shells.
4. Use your disposer “before” and “after” meals! While preparing food, turn on your disposer and the cold water, clearing your sink of vegetable peelings, or salad trimmings. When the meal is over, scrape food scraps directly into the disposer.
5. TO SPEED UP FOOD WASTE DISPOSAL... Cut or break up large bones, melon rinds, grapefruit skins, corn cobs. Items such as large bones, fibrous husks like lima bean pods and corn husks require considerable cutting time. For this reason, you may prefer to place them in the trash can or trash compactor along with your empty tin cans and bottles.

## 7. Troubleshooting

Before seeking repair or replacement, we recommend that you review the following:

**SAFETY NOTE:** Before investigating you must disconnect the power supply. Depending on the installation this can be done by either removing the plug from the socket or for continuous feed models, switching the disposer control to "OFF".

**LOUD NOISES:** (Other than those during grinding of bones and fruit pits): These are usually caused by accidental entry of a spoon, bottle cap or other foreign object. To correct this, remove \*splash guard and remove object with long handled tongs. Replace \*splash guard.

**UNIT DOES NOT START:** With \*splash guard removed, check to see if turntable will rotate freely using a wooden utensil. If turntable rotates freely, replace \*splash guard and check reset button to see if it has been tripped. Reset button is red and located opposite discharge elbow, near the bottom (see 7A). Push button in until it clicks and remains depressed.

If reset button has not been tripped, check for shorted or broken wire connecting to disposer. Check electrical power switch, fuse box or circuit breaker. If wiring and electrical components are intact, the unit may have internal problems that require service or replacement.

**IF TURNTABLE DOES NOT ROTATE FREELY:** Check for foreign object lodged between the turntable and grind ring. Dislodge object by rotating table with a wooden utensil and remove object (see 7B). If no foreign object is present, there may be internal problems.

**LEAKS:** If the unit leaks at the top, it may be due to:

1. Improper seating of sink flange (gasket choice, putty or tightening.)
2. Support ring not tightened properly.
3. Defective cushion mount.

If unit leaks at the waste elbow, leak may be due to improper tightening of elbow flange screws.

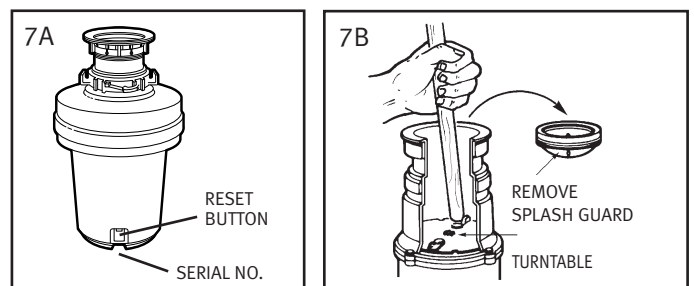

**WARNING:** Before resetting, disconnect the power supply - please see **SAFETY NOTE** above. The overload control prevents the motor from operating should overloading occur. This safety feature protects your house wiring and your disposer. When overloaded, the motor will stop automatically.

\*Splash guard is not used with Batch Feed or 3-Bolt Mount units.

## 8. Cleaning and maintenance

**The motor is permanently lubricated for life. Do not attempt to lubricate your Disposer!**

The disposer is self cleaning and scours itself with each use.

Your disposer, except for the Batch Feed model, is equipped with a removable splash guard for ease of cleaning or replacement. Remove splash guard by pulling it out from the top. To replace, simply insert into sink flange and push down until properly seated.

NEVER pour bleach or chemical drain cleaners into the disposer, as they cause serious corrosion of metal parts. If used, resulting damage can be easily detected and all warranties are void.

Mineral deposits from your water can form on the stainless steel turntable of your disposer, giving the appearance of rust. DO NOT BE ALARMED, the stainless steel turntables used on models indicated in section 10 will not corrode.

## 9. Electrical information

Replacing the fuse in moulded plugs:

The correct fuse cover must be refitted when changing the fuse. Remove the fuse cover and slide the fuse out.

Replace it with a 13 Amp ASTA fuse (approved to BS 1362).

Should the fuse cover be lost or damaged, an exact replacement should be used. Never use the plug without the fuse cover fitted.

**IMPORTANT:**

If the supply cord is damaged, it must be replaced by a qualified person in order to avoid hazard.

Franke UK Ltd

West Park MIOC

Styal Road

Manchester M22 5WB

Tel: 0161 436 6280 Fax: 0161 436 2180

info.uk@franke.com www.franke.co.uk

**Service & Spares:**

**UK Mainland & N. Ireland**

Tel: 0844 371 0195 Fax: 0844 371 0198

franke@servevastdirect.co.uk

**Republic of Ireland**

Tel: +353 1 413 6481 Fax: +353 1 413 6489

kalserve@kal.ie